



**THE CROMMELIN GROUP**

Innovation Powered by Experience



EDITION 2 - NOV 2018

**2018/19 PRODUCTS**





# GENERATORS

# CHOOSING YOUR GENERATOR.

Crommelins have been building generators for 60 years and have a range of quality generators for all industries. Commelins can offer a generator to your specific needs and can also customised.

## STANDARD GENERTOR

- Genuine Robin/Honda/Yanmar engine
- Australian fabricated steel frame.
- Quality AVR alternator
- 2 x Switched outlets

## CHOOSING THE CORRECT GENERATOR

1. Figure out what item/s need powering.
2. Add the total wattage of item/s together.
3. Determine the total wattage equals less than the maximum output of generator.  
For continuous loads use Cont. output.
4. Choose/Buy your generator

At start up, electric motors consume approximately 3 times the power requirement of the appliance. Make sure to check the generator continuous and/or its maximum output wattage when calculating power required.

Note: The initial 'start-up' power of some equipment/motors require 3x the wattage to get them running.

EQUIPMENT	WATTS RUNNING
SMART PHONE CHARGER	50
HAIR DRYER	1000-1500
MICROWAVE	1200+
KETTLE	1600-2000
HOUSEHOLD FRIDGE	300-600
PORTABLE FAN	40
COFFEE MAKER	1200
BELT SANDER	950
PRESSURE WASHER	1200
AIR COMPRESSOR	1400
CIRCULAR SAW	1500
SPACE HEATER	1000
CARAVAN AIR CONDITIONER	1500+
LAPTOP COMPUTER	500
9" ANGLE GRINDER	1500-2000
ELECTRIC DRILL 3/8"	500-700
TELEVISION	75-200
TOASTER	800-1250
WELDER 140A	5000
WATER PUMPS	275-1000
OVEN	4000-8000

BEST
  GOOD
  NOT RECOMMENDED

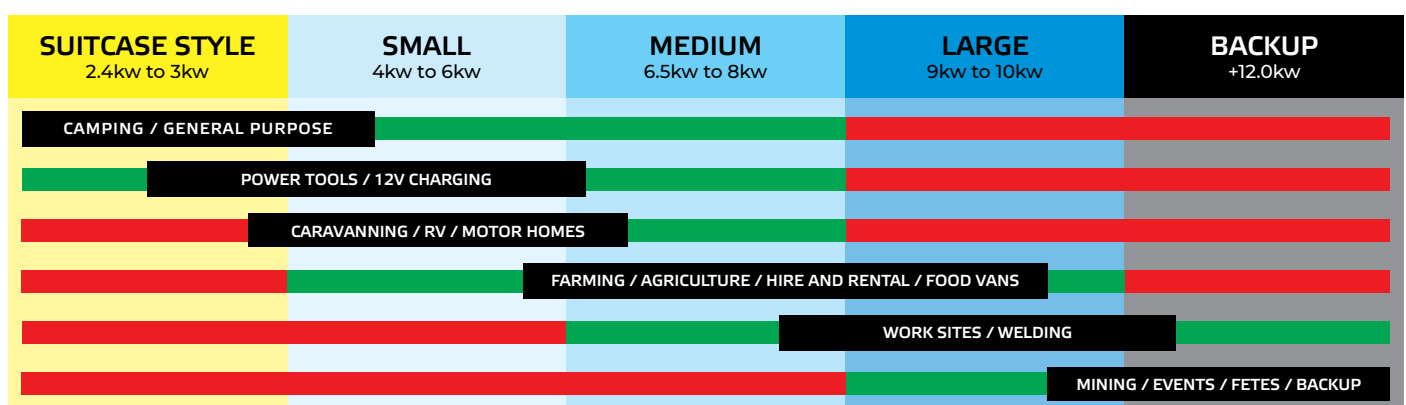

# CUSTOMISE YOUR GENERATORS.



Crommelins generators can be customised to suit most requirements and applications. Due to their proven reliability, high performance and customisation many Crommelins generators are prevalent in Hire Fleets.

## CUSTOM OPTIONS

- Long range fuel tanks (some models)
- Electric start with AGM battery
- Honda powered
- Lockable battery isolator
- Emergency stop button
- 4 x Wheels (solid, no-flat) with brakes
- 2, 4 and 6 wheel options
- Weatherproof (IP66) outlets
- Beacons
- Anderson jump plugs
- Recoil start locks
- Custom frame colouring
- Asset numbering and logo plate

## STANDARD HIREPACK

- Central lifting bar/hook
- 2 x Wheel kit
- Foldout transport handle
- Weatherproof outlets & RCD protection
- Earth spike & lead

## STANDARD MINE SPECIFICATION

- Hirepack
  - Electric start with AGM battery
  - Lockable battery isolator
  - Emergency stop button
  - Bunding
  - 1kg fire extinguisher
- \*Please confirm these specs meet your local Mine-site requirements when ordering

# ALTERNATORS EXPLAINED.

## ALTERNATOR BRANDS

- Sincro - Crommelins Generators
- Mecce Alte - Cromtech Generators
- Stamford - Crommelins standby generators

Below is a guide to help match the alternator to the application.

<p><b>STANDARD ALTERNATOR</b> (CONDENSER TYPE)</p>	<p>Suitable for power tools and resistive loads such as a kettle, a toaster, lights and other equipment not requiring a great accuracy of voltage control of power supply. A simple low maintenance design for basic equipment. Most generators come with a standard condenser type alternator.</p>
<p><b>AUTOMATIC VOLTAGE REGULATOR</b> (AVR)</p>	<p>Used for when power is required for more sensitive equipment and when the generator will be used to start electric motors. AVR alternators provide a more stable voltage output to compensate for the variation in voltage from load changes.</p>
<p><b>INVERTER</b> (ELECTRONIC VOLTAGE CONTROL)</p>	<p>For use with sensitive equipment such as computers. The inverter control system maintains an extremely high accuracy level of voltage and frequency fluctuation with very low wave distortion. The system also allows for the engine speed to be automatically adjusted in direct proportion to the load applied (econo-mode) maximizing fuel efficiency, while maintaining 240v supply.</p>

# CROMMELINS PETROL GENERATORS.



Crommelins has been building generators for 60 years that power most equipment for the Hire, Agricultural and Construction Industries as well as recreational markets. The Crommelins range of petrol generators are sized from 2800 to 8000 watts and you can order to hire spec.

## STANDARD FEATURES

- 32mm Australian fabricated steel frame
- Genuine Robin/Honda industrial engine
- Hirepack (2 x wheels, transport handle, lifting hook, weatherproof outlets with RCD protection)
- Earth leakage switch with earth spike
- IP66 Workplace compliant
- Sincro brushless alternator with overload protection
- 2 Years manufacturer's warranty
- Assembled and tested in Australia

## IDEAL FOR

- Hire and rental
- Farm and rural
- Backup Power
- Government Shires and councils
- Work sites

## OPTIONAL EXTRAS

- 3.5 kVA model CG35RPH
- Electric start with AGM battery
- Mine specification
- Honda powered
- Custom frame colouring
- Asset numbering and logo plate



	CG53RPH / P53H	CG64RPH / P64H	CH85RPH / P85H	CG100BEH / P100EH
<b>MAXIMUM OUTPUT (W)</b>	4240W	5000W	6800W	8000W
<b>CONTINUOUS OUTPUT (W)</b>	3800W	4800W	6200W	7500W
<b>STARTING SYSTEM</b>	RECOIL START	RECOIL START	RECOIL START	ELECTRIC START
<b>OUTLETS (SINGLE PHASE)</b>	1 X 10AMP, 1 X 15AMP	2 X 15AMP	2 X 15AMP	2 X 15AMP
<b>ALTERNATOR</b>	SINCRO	SINCRO	SINCRO	SINCRO
<b>VOLTAGE/FREQUENCY</b>	240V - 50HZ	240V - 50HZ	240V - 50HZ	240V - 50HZ
<b>ENGINE MODEL</b>	9HP EX27	12HP EX35	14HP EX40	16HP BS16HPES
<b>ENGINE BRAND</b>	ROBIN	ROBIN	ROBIN	VANGUARD
<b>FUEL TANK</b>	6L	7L	7L	8.4L
<b>RUNNING TIME (RATED OUTPUT)</b>	2.8HR	2.6HR	1.9HR	2HR
<b>DECIBELS @ 7M</b>	72db	76db	76db	76db
<b>WEIGHT (DRY)</b>	74KG	79KG	95KG	105KG
<b>DIMENSIONS (LxWxH)</b>	750 x 510 x 550MM	750 x 510 x 550MM	790 x 510 x 540MM	820 x 510 x 610MM
<b>MANUFACTURERS WARRANTY</b>	2 YEARS	2 YEARS	2 YEARS	2 YEARS

# CROMTECH PETROL GENERATORS.



Designed for general use, this trade range is perfect for the construction, agricultural, worksites and farming industries and will provide you with quality and durability with no fuss. Standard and Tradepack models are available.

### IDEAL FOR

- General purpose use
- Tradies and residential
- Farm and rural
- Construction and work sites

### STANDARD FEATURES

- 25mm Australian fabricated steel frame
- Genuine Robin/Honda industrial engine
- Mecc Alte brushless alternator
- Assembled and tested in Australia
- 2 Years manufacturer's warranty

### TRADEPACK INCLUDES

- Central lifting bar/hook
- 2 x Wheel kit
- Foldout transport handles
- IP66 Weatherproof outlets and RCD protection



### OPTIONAL EXTRAS (SOME MODELS)

- Honda powered
- Electric start
- Tradepack



	TG40RP / CTG40	TG60RP / CTG60	TG85RP / CTG85	TG100BE / CTG100E
<b>MAXIMUM OUTPUT (W)</b>	3200W	5000W	7000W	8000W
<b>CONTINUOUS OUTPUT (W)</b>	3000W	4700W	6400W	7500W
<b>STARTING SYSTEM</b>	RECOIL START	RECOIL START	RECOIL START	ELECTRIC START
<b>OUTLETS (SINGLE PHASE)</b>	2 X 10AMP	1 X 10AMP, 1 X 15AMP	2 X 15AMP	2 X 15AMP
<b>ALTERNATOR</b>	MECC ALTE	MECC ALTE	MECC ALTE	MECC ALTE
<b>VOLTAGE/FREQUENCY</b>	240V - 50HZ	240V - 50HZ	240V - 50HZ	240V - 50HZ
<b>ENGINE MODEL</b>	7HP EX21	9HP EX27	14HP EX40	16HP BS16HPES
<b>ENGINE BRAND</b>	ROBIN	ROBIN	ROBIN	VANGUARD
<b>FUEL TANK</b>	3.6L	6.1L	7L	8.4L
<b>RUNNING TIME (RATED OUTPUT)</b>	2.4HR	2.6HR	1.9HR	2.0HR
<b>DECIBELS @ 7M</b>	68db	70db	72db	76db
<b>WEIGHT (DRY)</b>	40KG	56KG	70KG	100KG
<b>DIMENSIONS (LxWxH)</b>	610 x 450 x 410MM	710 X 500 x 540MM	710 x 500 x 540MM	810 x 450 x 610MM
<b>MANUFACTURERS WARRANTY</b>	2 YEARS	2 YEARS	2 YEARS	2 YEARS

# CROMMELINS DIESEL GENERATORS.



Crommelins Diesel Generators are suitable for situations when it is not practical to have petrol powered generators, such as Mining and Oil Industry applications. They are low maintenance heavy duty industrial generators with the benefit of low running cost and durability over time..

## IDEAL FOR

- Hire and Rental
- Mining and Oil

## STANDARD FEATURES

- Electric Start with AGM battery
- Sincro brushless alternator
- IP66 Workplace compliant
- 32mm Australian fabricated steel frame
- 2 Years manufacturer's warranty
- Assembled and tested in Australia

## OPTIONAL EXTRAS

- Mine specification
- Long range fuel tank (16L)
- Anderson plugs
- Recoil start lock
- Custom frame colouring
- Asset numbering and logo plate



PHOTO WITH ROBIN ENGINE



PHOTO WITH ROBIN ENGINE



PHOTO WITH HATZ ENGINE

	CG32YDEH / D32YEH	CG69YDEH / D69YEH	CG80ZDEH / D8EH	CG80YDEH / D8YEH
<b>MAXIMUM OUTPUT (W)</b>	2400W	5500W	6000W	5600W
<b>CONTINUOUS OUTPUT (W)</b>	2000W	4400W	5000W	5000W
<b>STARTING SYSTEM</b>	ELECTRIC START	ELECTRIC START	ELECTRIC START	ELECTRIC START
<b>OUTLETS (SINGLE PHASE)</b>	2 X 10AMP	2 X 15AMP	2 X 15AMP	2x 15AMP
<b>ALTERNATOR</b>	SINCRO	SINCRO	SINCRO	SINCRO
<b>VOLTAGE/FREQUENCY</b>	240V - 50HZ	240V - 50HZ	240V - 50HZ	240V - 50HZ
<b>ENGINE MODEL</b>	4.7HP L48	10HP L100	10.5HP IB40	10HP L100
<b>ENGINE BRAND</b>	YANMAR	YANMAR	HATZ	YANMAR
<b>FUEL TANK</b>	2.4L	5.4L	5L	5.4L
<b>DECIBELS @ 7M</b>	94db @ 1M	97db @ 1M	82db	97db @ 1M
<b>WEIGHT (DRY)</b>	85KG	116KG	126KG	125KG
<b>DIMENSIONS (LxWxH)</b>	710 x 450 x 530MM	840 x 520 x 640MM	920 x 710 x 950MM	920 x 710 x 950mm
<b>MANUFACTURERS WARRANTY</b>	2 YEARS	2 YEARS	2 YEARS	2 YEARS



# CROMTECH LEISURE GENERATORS.



Crommelins have hand selected this range of quality inverter generators for the recreational and domestic use. These generators come with multiple power options, are petrol powered and come with an eco-mode for economical operation.

## IDEAL FOR

- Camping, caravanning & RVs
- Portable fridge/freezer
- Home and small office backup power
- Precision instruments
- Small power tools
- Fetes and markets

## CTG2500I FEATURES

- Bonus dust cover
- Lightest model in its class



	<b>CTG2500I</b>
<b>MODEL NAME</b>	CROMTECH OUTBACK
<b>MAXIMUM OUTPUT (W)</b>	2400W
<b>CONTINUOUS OUTPUT (W)</b>	2100W
<b>STARTING SYSTEM</b>	RECOIL START
<b>OUTLETS (SINGLE PHASE)</b>	2 X 15AMP
<b>VOLTAGE/FREQUENCY</b>	230V - 50HZ
<b>USB POWER OUTPUT</b>	2X USB (5V)
<b>12V POWER OUTPUT</b>	12V-8AMP
<b>ENGINE MODEL</b>	2.6KW CROMTECH (79CC)
<b>FUEL TANK</b>	5L
<b>DECIBELS @ 7M</b>	52 - 59db
<b>RUNNING TIME (LOAD DEPENDING)</b>	5 TO 20HRS
<b>WEIGHT (DRY)</b>	19.8KG
<b>DIMENSIONS (LxWxH)</b>	512 x 315 x 447MM
<b>MANUFACTURERS WARRANTY</b>	1 YEAR

## STANDARD FEATURES

- 2 x Outlets
- USB Outlets
- Main LED sensors (low oil alarm, overload protection, output light)
- Eco-mode adjusts output as load requires and lowers noise
- AC Reset button
- 4-Stroke, Forced air cooled, OHV, recoil start
- Pure Sine wave
- Easy maintenance with convenient access ports
- 1 year domestic use Cromtech warranty

## CTG3000I FEATURES

- Digital Display (Volts, Hz, Kw, Hrs)
- Extendable handle
- Large rubber wheels



	<b>CTG3000I</b>
<b>MODEL NAME</b>	CROMTECH BRUMBY
<b>MAXIMUM OUTPUT (W)</b>	3000W
<b>CONTINUOUS OUTPUT (W)</b>	2800W
<b>STARTING SYSTEM</b>	RECOIL START
<b>OUTLETS (SINGLE PHASE)</b>	2 X 15AMP
<b>VOLTAGE/FREQUENCY</b>	230V - 50HZ
<b>USB POWER OUTPUT</b>	2X USB (5V)
<b>12V POWER OUTPUT</b>	12V-6AMP
<b>ENGINE MODEL</b>	5.4HP CROMTECH (205CC)
<b>FUEL TANK</b>	10.5L
<b>DECIBELS AT 7M</b>	64 - 76db
<b>RUNNING TIME (LOAD DEPENDING)</b>	8HRS (25% LOAD)
<b>WEIGHT (DRY)</b>	40KG
<b>DIMENSIONS (LxWxH)</b>	690 x 415 x 500MM
<b>MANUFACTURERS WARRANTY</b>	1 YEAR

# CROMMELINS WELDER GENERATORS.



PHOTO  
SHOWN WITH  
HIREPACK

Crommelins Welder Generators are a convenient combination of Arc Welding and power generation. This unit is ideally suited to rental and agricultural industries for small on-site repairs. These models can be customised to suit your requirements.

## STANDARD FEATURES

- Welder Sincro brushless alternator
- Genuine Robin/Yanmar industrial engine
- Electric start with AGM battery
- Workplace compliant
- 32mm Australian fabricated steel frame
- 2 Years manufacturer's warranty
- Assembled and tested in Australia

## IDEAL FOR

- Hire and rental
- Mining and oil
- Farm and rural
- Shires and councils

## OPTIONAL EXTRAS

- Electric start with AGM battery
- Hire pack
- Mine specification
- Long range fuel tank
- Anderson plugs
- Recoil start lock
- Welding leads



**GW200RP / 3P200**

<b>WELDING AMPS (A)</b>	60 TO 200AMP
<b>FUEL TYPE</b>	PETROL
<b>MAXIMUM OUTPUT (W)</b>	5600W
<b>CONTINUOUS OUTPUT (W)</b>	4480W
<b>STARTING SYSTEM</b>	RECOIL START
<b>OUTLETS (SINGLE PHASE)</b>	2 X 15AMP
<b>ALTERNATOR</b>	SINCRO
<b>VOLTAGE/FREQUENCY</b>	240V - 50HZ
<b>ENGINE MODEL</b>	14HP EX40
<b>ENGINE BRAND</b>	ROBIN
<b>FUEL TANK</b>	7L
<b>RUNNING TIME (RATED OUTPUT)</b>	1.9HR
<b>DECIBELS @ 7M</b>	72db
<b>WEIGHT (DRY)</b>	83KG
<b>DIMENSIONS (LxWxH)</b>	820 x 510 x 540MM
<b>MANUFACTURERS WARRANTY</b>	2 YEARS



PHOTO  
WITH ROBIN  
ENGINE

**GW180YDE**

<b>WELDING AMPS (A)</b>	60 TO 180AMP
<b>FUEL TYPE</b>	DIESEL
<b>MAXIMUM OUTPUT (W)</b>	4000W
<b>CONTINUOUS OUTPUT (W)</b>	3200W
<b>STARTING SYSTEM</b>	ELECTRIC START
<b>OUTLETS (SINGLE PHASE)</b>	1 X 10AMP, 1 X 15AMP
<b>ALTERNATOR</b>	SINCRO
<b>VOLTAGE/FREQUENCY</b>	240V - 50HZ
<b>ENGINE MODEL</b>	10HP L100
<b>ENGINE BRAND</b>	YANMAR
<b>FUEL TANK</b>	5.4L
<b>RUNNING TIME (RATED OUTPUT)</b>	-
<b>DECIBELS @ 7M</b>	97db @ 1M
<b>WEIGHT (DRY)</b>	114KG
<b>DIMENSIONS (LxWxH)</b>	840 x 520 x 640MM
<b>MANUFACTURERS WARRANTY</b>	2 YEARS

# CROMTECH WELDER GENERATOR.



The 200amp CROMTECH™ welder generators are powered by a Robin engine and has a low maintenance Italian Mecc Alte Alternator. The model comes in an Australian made steel roll frame.

## STANDARD FEATURES

- Welder Mecc Alte brushless alternator
- Genuine Robin industrial engine
- Double switched power outlets
- 25mm Australian fabricated steel frame
- Overload protection
- 2 Years manufacturer's warranty
- Australian assembled and tested



## IDEAL FOR

- Farm maintenance
- General purpose use
- Welding on-site
- Backup power

## OPTIONAL EXTRAS

- Electric start with AGM battery
- Trade pack
- Honda powered
- Welding leads



	<b>TGW200RP / CTGW200</b>
<b>WELDING AMPS (A)</b>	60 TO 200A
<b>FUEL TYPE</b>	PETROL
<b>MAXIMUM OUTPUT (W)</b>	5600W
<b>CONTINUOUS OUTPUT (W)</b>	4480W
<b>STARTING SYSTEM</b>	RECOIL START
<b>OUTLETS (SINGLE PHASE)</b>	2 X 15AMP
<b>ALTERNATOR</b>	MECC ALTE
<b>VOLTAGE/FREQUENCY</b>	240V - 50HZ
<b>ENGINE MODEL</b>	14HP EX40
<b>ENGINE BRAND</b>	ROBIN
<b>FUEL TANK</b>	7.0L
<b>RUNNING TIME (RATED OUTPUT)</b>	1.9HR
<b>DECIBELS @ 7M</b>	72DB
<b>WEIGHT (DRY)</b>	82KG
<b>DIMENSIONS (LxWxH)</b>	710 x 500 x 540MM
<b>MANUFACTURERS WARRANTY</b>	1 YEAR

# CROMMELINS WORKSTATION GENERATORS.



The perfect combination for a mobile workshop or service vehicle. The Generator, Welder, Air Compressor is a convenient model all built into an Australian fabricated steel frame, making it easy to move from site to site.

## STANDARD FEATURES

- 40L Air compressor (7.7cfm)
- Power generation
- Electric start with AGM battery
- Weatherproof outlets with RCD
- Sincro brushless alternator
- 33mm Australian fabricated steel frame
- Cable holders and lifting hook
- 5 metre welding leads
- 2 Years manufacturer's warranty
- Assembled and tested in Australia



## IDEAL FOR

- Agriculture
- Air compressor equipment
- Welding on-site
- Multi-purpose use
- Service vehicles

## OPTIONAL EXTRAS

- Mine specification
- Hire pack
- Long range fuel tank
- Battery charger



PHOTO WITH ROBIN ENGINE

	WS200RPEH / 3P200E41
WELDING AMPS (A)	60 TO 200A
AIR COMPRESSOR FLOW RATE (CFM)	7.7CFM
FUEL TYPE	PETROL
MAXIMUM OUTPUT (W)	5600W
CONTINUOUS OUTPUT (W)	4480W
STARTING SYSTEM	ELECTRIC START
OUTLETS (SINGLE PHASE)	2 X 15AMP
ALTERNATOR	SINCRO
VOLTAGE/FREQUENCY	240V - 50HZ
ENGINE MODEL	14HP EX40
ENGINE BRAND	ROBIN
FUEL TANK	7.0L
RUNNING TIME (RATED OUTPUT)	1.9HR
DECIBELS @ 7M	72db
WEIGHT (DRY)	143KG
DIMENSIONS (LxWxH)	930 x 830 x 720MM
MANUFACTURERS WARRANTY	2 YEARS

	WS180YDEH / 3D180YE41
WELDING AMPS (A)	60 TO 180A
AIR COMPRESSOR FLOW RATE (CFM)	7.7CFM
FUEL TYPE	DIESEL
MAXIMUM OUTPUT (W)	4000W
CONTINUOUS OUTPUT (W)	3200W
STARTING SYSTEM	ELECTRIC START
OUTLETS (SINGLE PHASE)	1 X 10AMP, 2 X 15AMP
ALTERNATOR	SINCRO
VOLTAGE/FREQUENCY	240V - 50HZ
ENGINE MODEL	10HP L100
ENGINE BRAND	YANMAR
FUEL TANK	5.4L
RUNNING TIME (RATED OUTPUT)	-
DECIBELS @ 7M	97db @ 1M
WEIGHT (DRY)	170KG
DIMENSIONS (LxWxH)	930 x 830 x 720MM
MANUFACTURERS WARRANTY	2 YEARS

# CROMMELINS STANDBY GENERATORS.



Crommelins have put the big brand names you can trust together and now offer standby generator sets powered by a Kubota water cooled diesel engines and Stamford alternators with Deep Sea controllers. This range is ideal for most of those worksite, home and solar power backup needs with each model having switched single and three phase outlets for instant use.

## STANDARD FEATURES

- Switched outlets with RCD circuit breakers
- Kubota diesel engine
- Deep Sea controller
- Stamford alternator (4 Pole AVR)
- Remote start and hardwire facility
- Bunded canopy with lockable doors & fuel cap
- Auto transfer switch socket
- Central lifting hook & forklift pockets
- Easy access panels for service and maintenance
- 50°C Rated radiator suits Australian conditions
- 2 Year Kubota engine warranty (2000hrs)
- 1 Year Stamford alternator warranty (1000hrs)
- 1 Year manufacturers warranty

## IDEAL FOR

- Event Hire
- Rental
- Residential
- Commercial

## OPTIONAL EXTRAS

- Auto transfer switch



	CHK13S	CHK13S3	CHK20S3	CHK30S3
<b>MAX. PRIME OUTPUT (KVA / KW)</b>	13KVA / 10.8KW	13KVA / 10.8KW	17KVA / 13.6KW	30KVA / 24KW
<b>CONT. STANDBY OUTPUT (KVA / KW)</b>	14KVA / 11.2KW	14KVA / 11.2KW	19KVA / 15.2KW	33KVA / 26.4KW
<b>PHASE</b>	SINGLE	THREE	THREE	THREE
<b>OUTLETS (SINGLE / THREE PHASE)</b>	2 X 15AMP	1 X 15AMP, 1 X 32AMP 3P	1 X 15AMP, 1 X 32AMP 3P	1 X 15AMP, 1 X 32AMP 3P
<b>ALTERNATOR</b>	STAMFORD PI144E	STAMFORD PI044G	STAMFORD PI144D	STAMFORD PI144G
<b>OUTPUT AMPS</b>	54.2 / 58.3 AMPS	18.1 / 19.5 AMPS	23.7 / 26 AMPS	41.7 / 45.9 AMPS
<b>DEEPSEA CONTROLLER</b>	DEEPSEA DSE6020	DEEPSEA DSE6020	DEEPSEA DSE6020	DEEPSEA DSE6020
<b>AUTO TRANSFER SOCKET</b>	YES	YES	YES	YES
<b>2 WIRE REMOTE START</b>	YES	YES	YES	YES
<b>ENGINE BRAND / MODEL</b>	KUBOTA D1703-BG	KUBOTA D1703-BG	KUBOTA V2203-BG	KUBOTA V3300-BG
<b>FUEL TANK</b>	55L	55L	65L	90L
<b>RUNNING TIME (RATED OUTPUT)</b>	24HR	28HR	26HR	24HR
<b>DECIBELS @ 7M</b>	64db	63db	64db	65db
<b>WEIGHT (DRY)</b>	625KG	601KG	646KG	910KG
<b>DIMENSIONS (LxWxH)</b>	1782 x 868 x 1115MM	1782 x 868 x 1115MM	1834 x 868 x 1115MM	2000 x 925 x 1300MM
<b>MANUFACTURERS WARRANTY</b>	1 YEAR	1 YEAR	1 YEAR	1 YEAR

**MODEL COMING  
IN 2019**

# CROMTECH AVR GENERATOR.

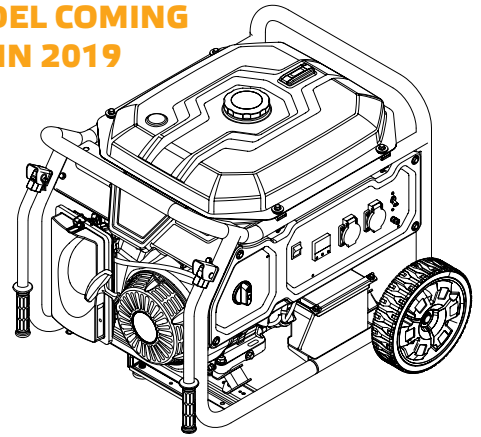

Designed for general use, this trade range is perfect for the construction, agricultural, worksites and farming industries and will provide you with quality and durability with no fuss. Standard and Tradepack models are available.

## IDEAL FOR

- General purpose use
- Tradies and residential
- Farm and rural
- Fetes and markets

## STANDARD FEATURES

- 2x Outlets (single phase - 15 Amp)
- Electric start and recoil start
- Fold-out handles
- Steel frame with large wheels
- 4-Stroke, air cooled, OHV engine
- Hours operation, Hz, Voltage meter
- Battery charging (12V-8.3Amp)
- Low oil alarm, overload alarm, output indicator
- Large 25L fuel tank
- 1 Year Cromtech warranty



	<b>TG6500VE</b>
<b>MAXIMUM OUTPUT (W)</b>	6500W
<b>CONTINUOUS OUTPUT (W)</b>	6000W
<b>STARTING SYSTEM</b>	ELECTRIC START
<b>OUTLETS (SINGLE PHASE)</b>	2 X 15AMP
<b>VOLTAGE/FREQUENCY</b>	230V - 50HZ
<b>12V POWER OUTPUT</b>	12V-8.3AMP
<b>ENGINE MODEL</b>	CROMTECH (420cc)
<b>OIL CAPACITY (L)</b>	1.1L
<b>FUEL TANK</b>	25L
<b>DECIBELS @ 7M</b>	74db
<b>WEIGHT (DRY)</b>	87KG
<b>DIMENSIONS (LxWxH)</b>	715 x 545 x 605MM
<b>MANUFACTURERS WARRANTY</b>	1 YEAR



# WARRANTY



### **3 YEAR ROBIN ENGINE WARRANTY**

Robin Industrial Engines and Robin Imported Products (Pumps, Generators) come with a 3 year manufacturer's warranty.



### **2 YEAR MANUFACTURER'S WARRANTY**

CROMMELINS™ brand products powered by a Robin Industrial Engine come with a 2 year manufacturer's warranty.



### **1 YEAR MANUFACTURER'S WARRANTY**

All other products including CROMMELINS™, CROMTECH™, flexible drive products (ie FP2T), high pressure pumps and imported products come with a 1 year manufacturer's warranty.



### **OTHER BRANDS WARRANTY**

Other branded products come with warranties provided by their manufacturer, ie. Golz, American Sanders, AR Blue Clean.

—  
**AWARD WINNING  
SERVICE &  
BACKUP**



# WARRANTY EXPLAINED

Crommelins Machinery warrants their goods against defects in materials and workmanship under normal use and service.

The Crommelins Machinery warranty does not cover fair wear commensurate with the age of the product, any damage caused by accident, abuse, misuse, neglect or failure to observe proper operating instructions or proper machinery maintenance as described in the instruction manual.

It is the owners responsibility to regularly maintain a product in accordance with the owners manual and only use the equipment for its designed purpose.

Our goods come with guarantees that cannot be excluded under the Australian Consumer Law. You are entitled to a replacement or refund for a major failure and for compensation for any other reasonably foreseeable loss or damage. You are also entitled to have goods repaired or replaced if the goods fail to be of acceptable quality and the failure does not amount to a major failure.

## CONSUMER ADVICE

Any claim under these warranties must be made within warranty period from the date of purchase of the product.

To make a claim under the warranty, you must return the product (with proof of purchase) to the closest warranty agent or to the place of purchase.

Where a failure does not amount to a major failure, Crommelins Machinery is entitled to choose between providing you with a repair, replacement or refund. To obtain compensation, you would need to provide documentary evidence of the loss or damage suffered, and documentary evidence that such loss or damage was a reasonably foreseeable consequence of a failure by Crommelins Machinery to comply with a consumer guarantee under the Australian Consumer Law.

CROMMELINS™, CROMTECH™, CROMTECH OUTBACK™, CROMMELINS FINANCE™, DOLPHIN™ is registered trademarks of Crommelins Operations Pty Ltd, trading as The Crommelin Group.

## SERVICE AGENTS

There are over 185 national authorised service/repair agents available, visit [www.crommelins.com.au](http://www.crommelins.com.au) for their details and locations. For engine brands other than Robin please contact the manufacturer for service agents.

## CROMMELINS PRODUCTS

Crommelins takes pride in all products they sell and they live by their company Mission Statement; "To be the supplier of choice to Hire and Construction Industry by providing high quality portable powered products."

## THE CROMMELIN GROUP

ABN 11 008 889 656  
PO Box 352, BENTLEY WA 6982

**PH** (08) 9350 5588

**FAX** (08) 9451 6381

**E** [email@crommelins.com.au](mailto:email@crommelins.com.au)

**CROMMELINS™**  
EST. 1958  
MACHINERY

**CROMMELINS™**  
EST. 1958  
MACHINERY

SALES  
&  
SPARE  
PARTS





CROMMELINS  
AUSTRALIA



CROMMELINS  
QUALITY PORTABLE POWER PRODUCTS

